

"CMA" MODEL w/DUAL SHAFT

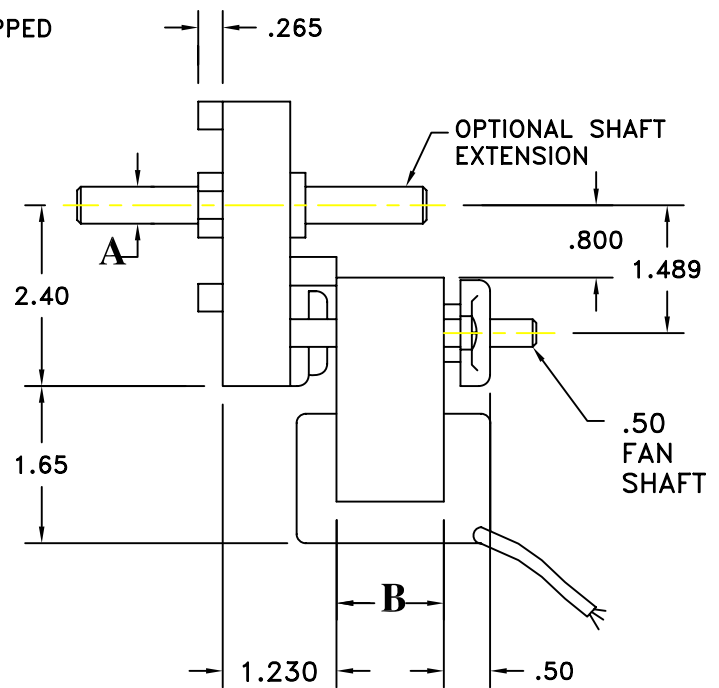
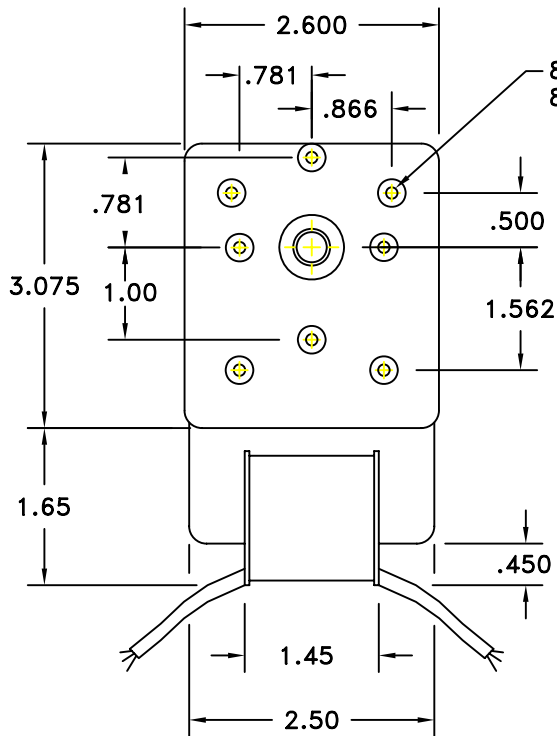

AC UNIDIRECTIONAL GEARMOTOR

A- OUTPUT SHAFT DIAMETER & LENGTH PER CUSTOMER REQUIREMENTS.

B- FROM 5/8" TO 2" DEPENDING UPON R.P.M. AND TORQUE

- * OUTPUT SPEED FROM 2 - 500 RPM
- * OUTPUT TORQUE TO 50 IN. LB.
- * 24/120/240 VAC/ 50/60 HZ
- * CONTINUOUS OR INTERMITTANT DUTY
- * SELF-RESETTING THERMAL PROTECTION
- * U.L., C.S.A. & T.U.V. APPROVED
- * 18 GAUGE LEADS

OPTIONS:

HIGH TEMPERATURE PLASTIC FAN,
2 1/2" ϕ x 3/4" THICK
HEAVY DUTY NEEDLE BEARINGS
FRICTION BRAKES
TERMINALS
ONE WAY CLUTCH

REX ENGINEERING CORP.

TITUSVILLE, FL(321)268-5500