

"CPA" MODEL

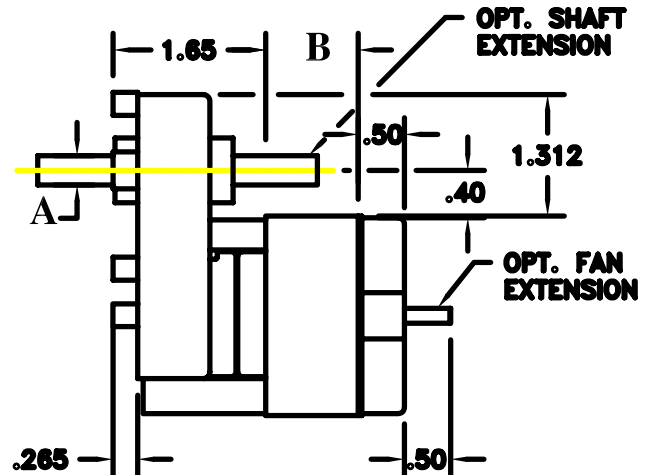
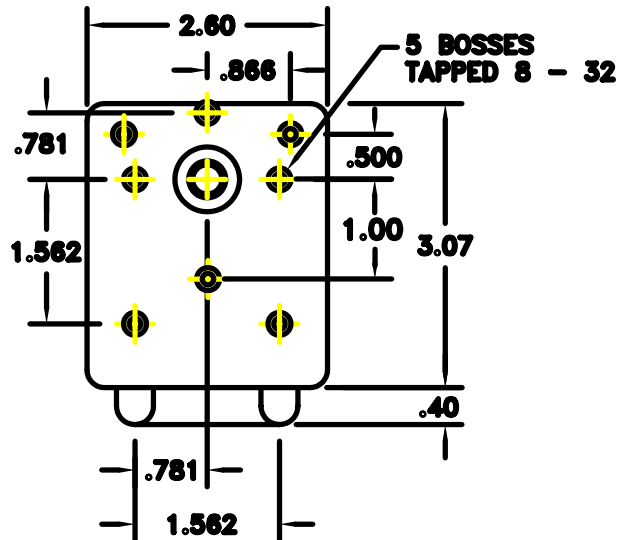

AC REVERSABLE GEARMOTOR

A - OUTPUT SHAFT DIAMETER & LENGTH PER CUSTOMER REQUIREMENTS.

B - FROM 5/8" TO 2" DEPENDING UPON R.P.M. AND TORQUE REQUIREMENTS.

- * OUTPUT SPEED FROM 2 - 500 RPM
- * OUTPUT TORQUE TO 50 IN. LB.
- * 24/120/240 VAC/ 50/60 HZ
- * CONTINUOUS OR INTERMITTANT DUTY
- * SELF-RESETTING THERMAL PROTECTION
- * U.L. & C.S.A. APPROVED
- * 3 WIRE, PERMANENT SPLIT CAPACITOR CONSTRUCTION
- * 18 GAUGE LEADS

OPTIONS:

HIGH TEMPERATURE PLASTIC FAN,
1 7/8" ϕ x 3/8" THICK
HEAVY DUTY NEEDLE BEARINGS
CAPACITOR
FRICTION BRAKES
TERMINALS

REX ENGINEERING CORP.

TITUSVILLE, FL(321)268-5500